

## FILTERMIST FX SERIES FX5002 - OIL MIST FILTERS



### TECHNICAL SPECIFICATION

Airflow (m <sup>3</sup> /h)	1675 @ 50Hz 2000 @ 60Hz
Motor	1.5kW 50Hz 200v, 220v, 380v, 400v 1.5kW 60Hz 200v, 220v, 230v, 440v, 460v, 480v
A (mm)	357
B (mm)	634.5
C (mm)	35
D (mm)	198
E (mm)	378
F (mm)	398
Weight	31.8 kg
Noise Level	71 dB(A)

### DESCRIPTION

Filtermist FX5002 units efficiently remove oil & coolant mist, fume and steam in a various amount of manufacturing operations around the world.

Can be directly connected to the machining centre or fixed on a stand with easy access for maintenance.

### DIMENSIONS

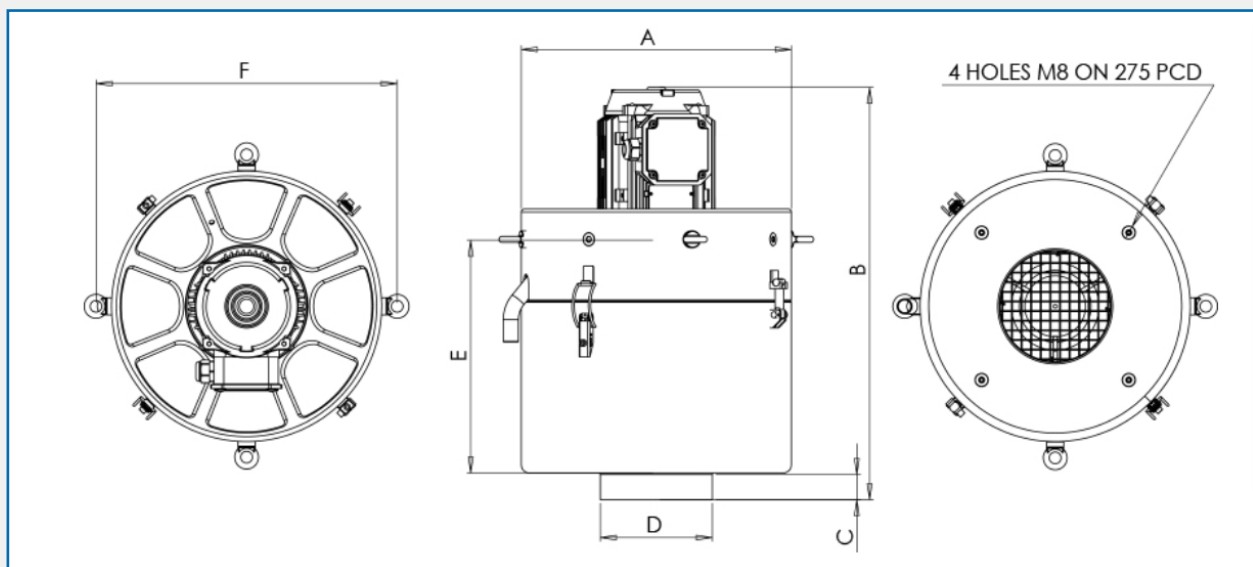

AES OFFER INSTALLATION AND SERVICE SUPPORT FOR ALL EQUIPMENT